

FEATURES

- ✘ Compact-sized 2.6x3mm
- ✘ Low profile with 0.45mm / 0.65mm

APPLICATION

- ✘ Smart phone
- ✘ Digital camera, Medical
- ✘ Portable electronic device

SPECIFICATION

Contact Rating	50mA, 12V DC
Contact Resistance	500mΩ max.
Insulation Resistance	50MΩ min. 100V DC
Dielectric Strength	250V AC/1 minute
Operating Force	100±50gf, 160±50gf
Travel	0.15mm
Operating Life	100,000 cycles
Operating Temp.	-40°C ~ +85°C
Storage Temp.	-40°C ~ +85°C

HOW TO ORDER

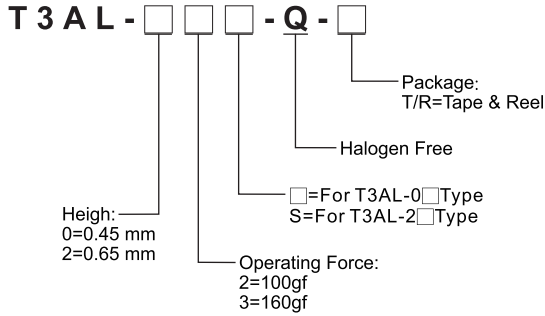

CIRCUIT

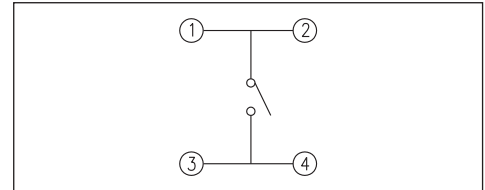

PACKAGE

<Tape & Reel>
8000 pcs

TACT SWITCH

T3AL-0[]

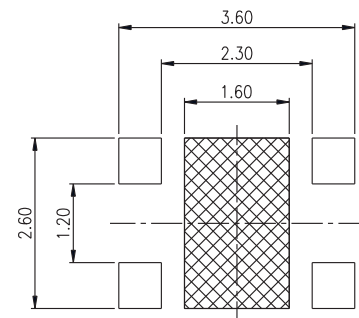
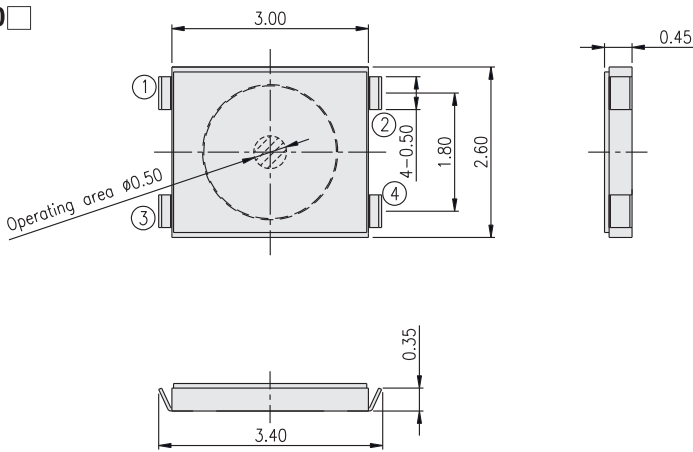

Any land pattern or vias shall not be provided at 1.6X2.6 area.

P.C.B. LAYOUT

T3AL-2[]S

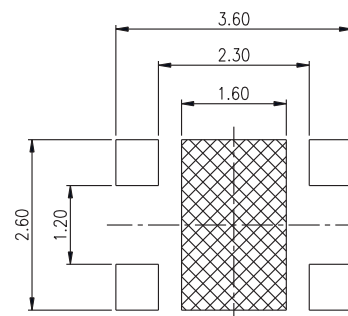
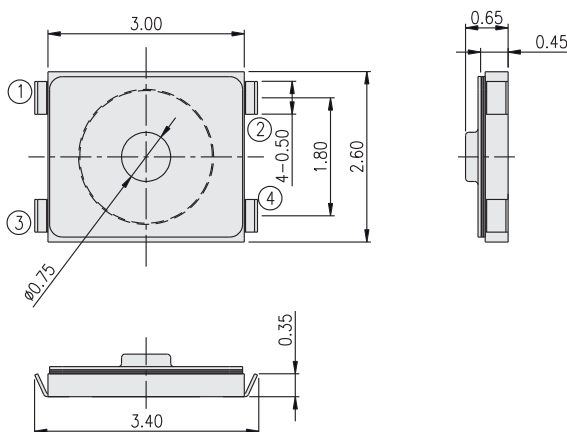

Any land pattern or vias shall not be provided at 1.6X2.6 area.

P.C.B. LAYOUT